

Fig. 1a Tub Head Cross-Section

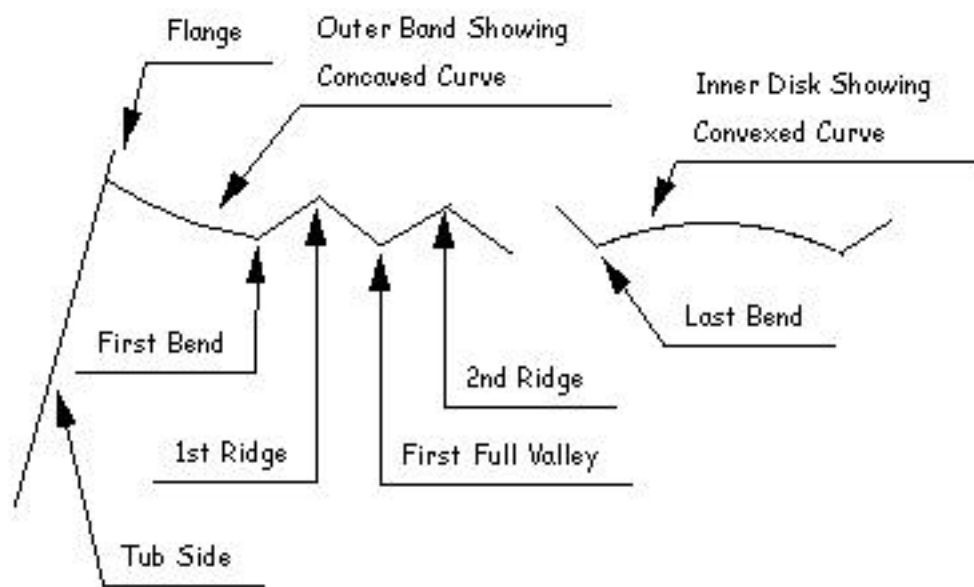
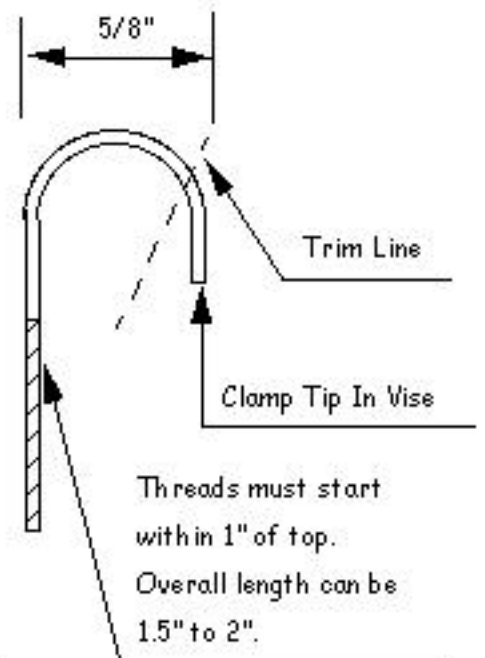

Fig. 1b

Trimming J-Bolt



PATTERNS PAGE 1

@lfmiller10/15/02

Fig. 1c

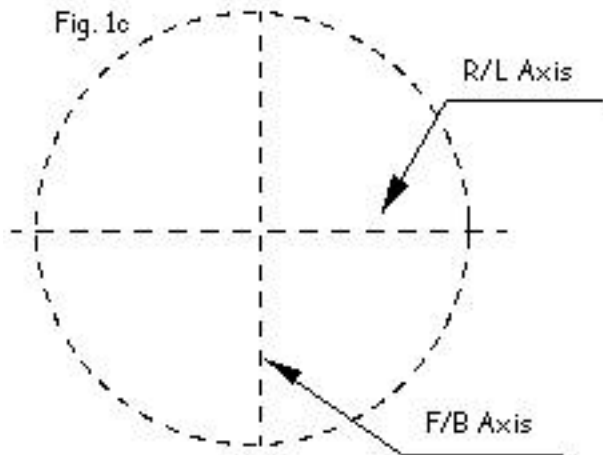

Outline on Work Surface.

Fig. 1d

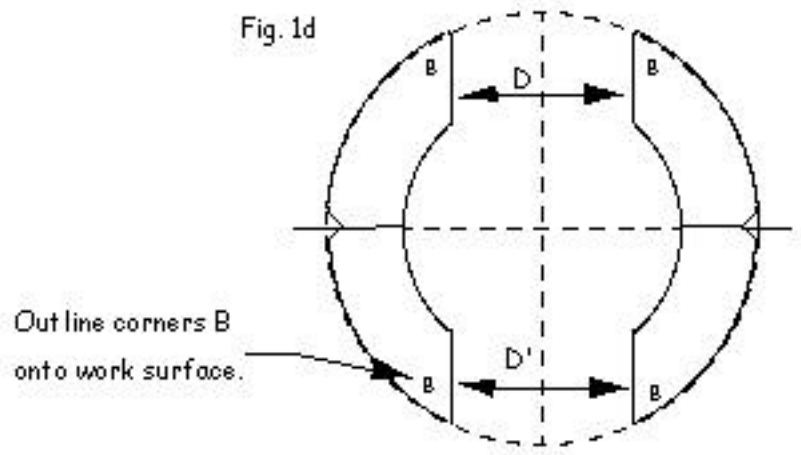

R/L Pieces in Place

Fig. 1e

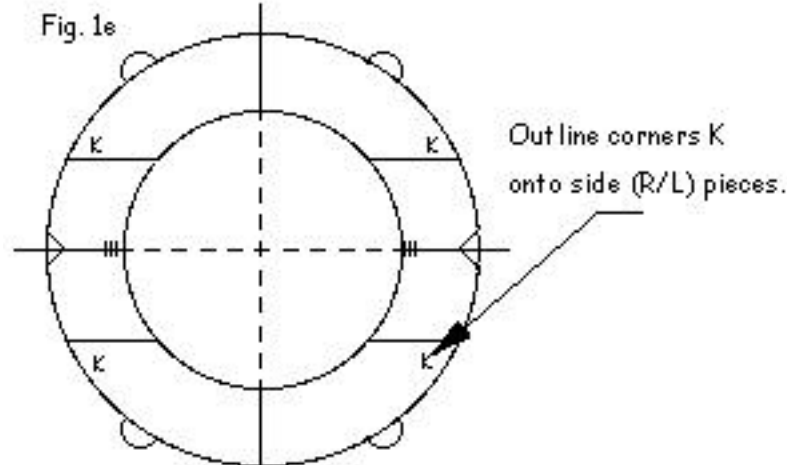

F/B Pieces Atop R/L Pieces

Fig. 1f

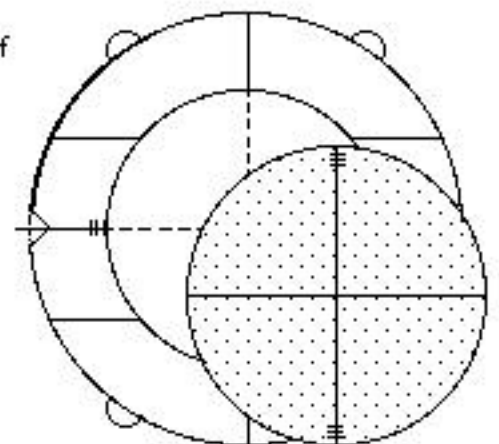

Back Panel Ready for Installation

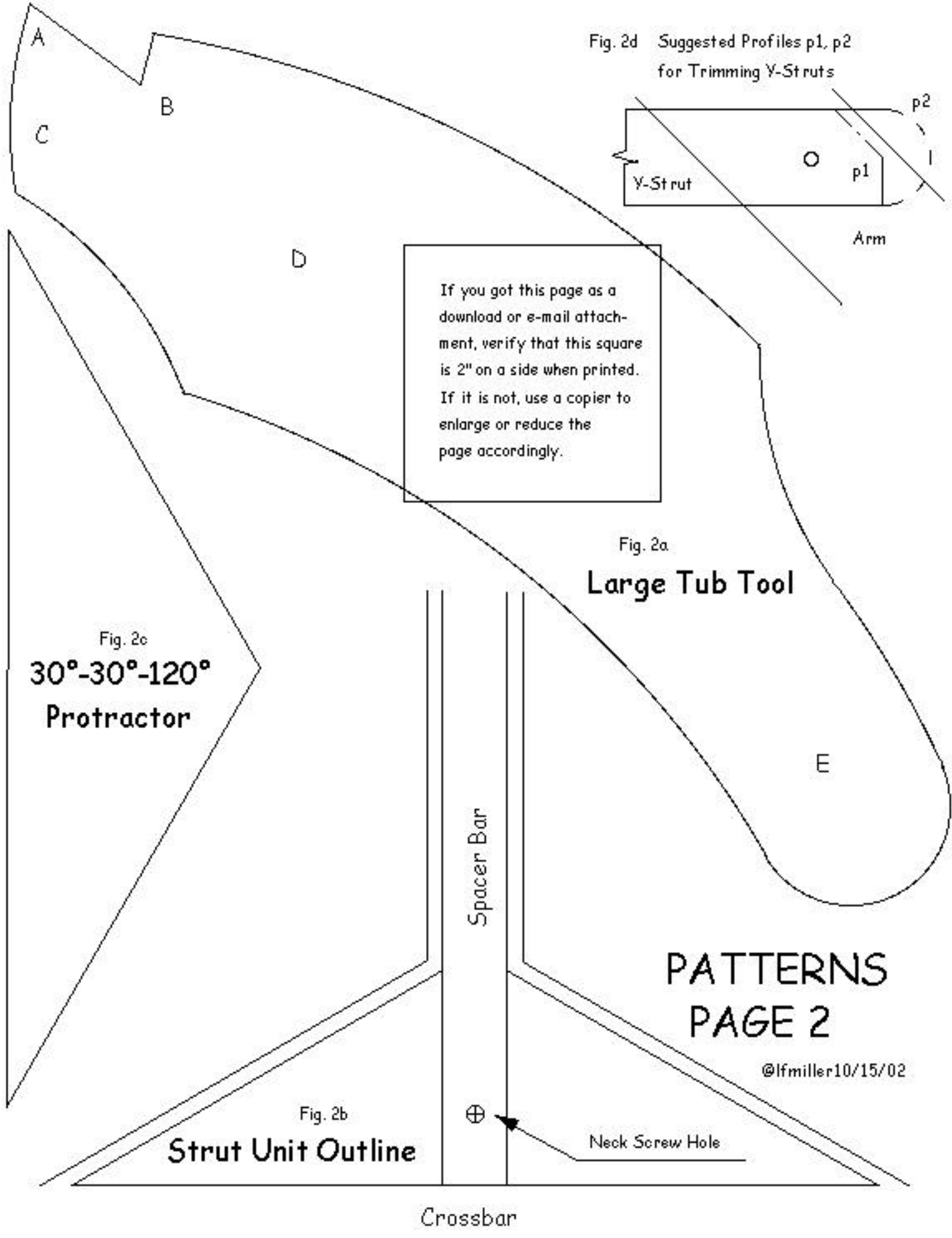

Fig. 2d Suggested Profiles p1, p2 for Trimming Y-Struts

If you got this page as a download or e-mail attachment, verify that this square is 2" on a side when printed. If it is not, use a copier to enlarge or reduce the page accordingly.

Fig. 2a

Large Tub Tool

Fig. 2c

**30°-30°-120°
Protractor**

**PATTERNS
PAGE 2**

@lfmiller10/15/02

Fig. 2b

Strut Unit Outline

Spacer Bar

Crossbar

Neck Screw Hole

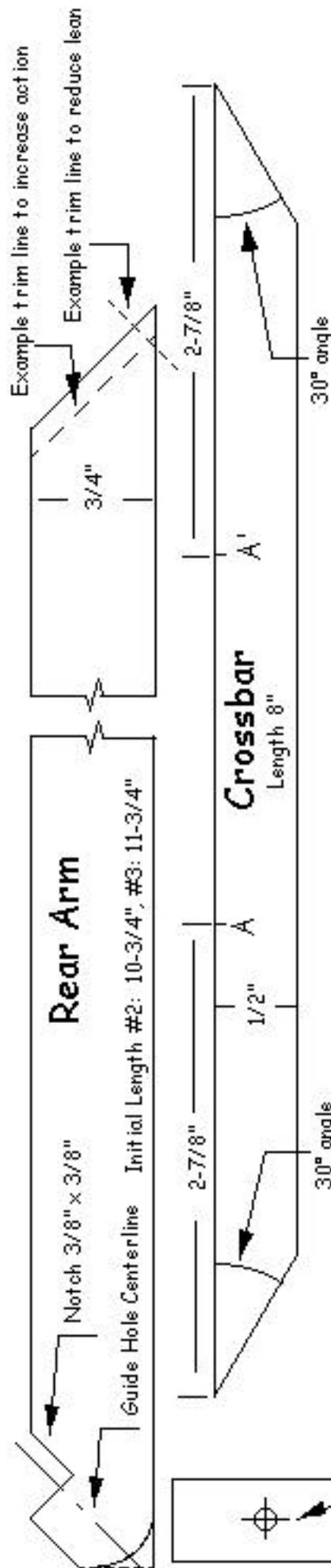
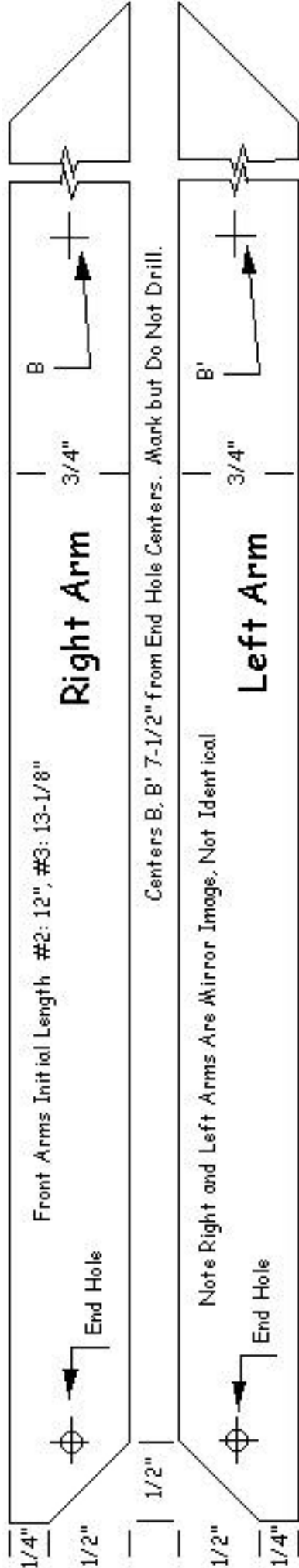

Crossbar, Spacer, and Arms All 1/2" x 3/4" Parting Stop

PATTERNS PAGE 3

@lfmiller10/15/02

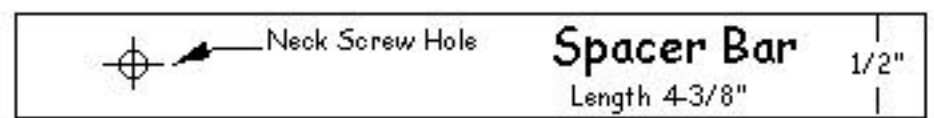

Crossbar Mitering Techniques

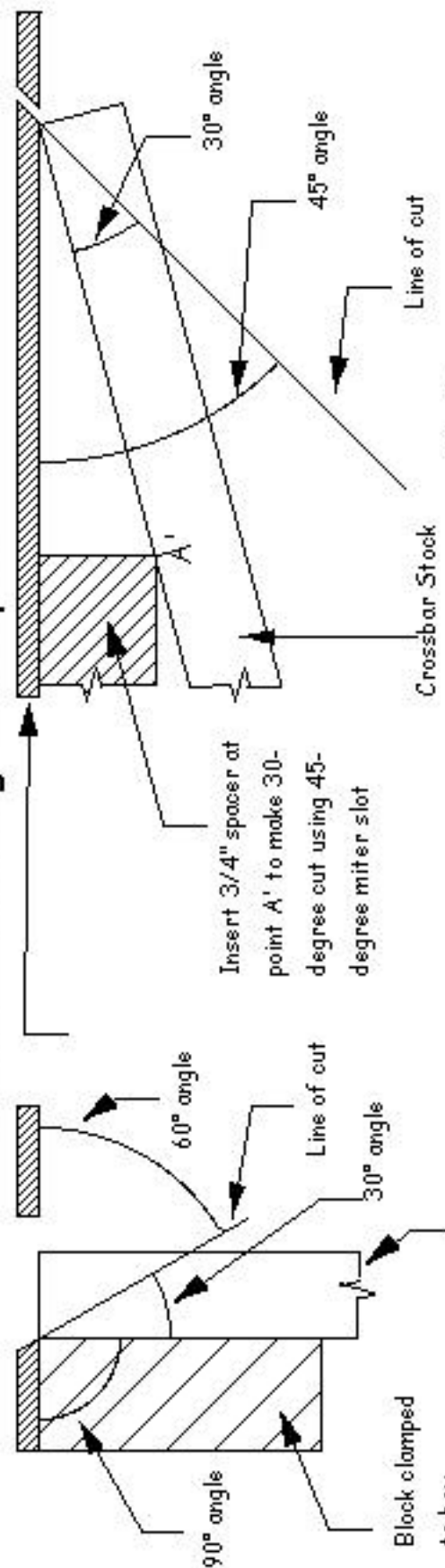

Fig. 3b

Fig. 3a Crossbar Stock

If you got this page as a download or e-mail attachment, verify that this square is 2" on a side when printed. If it is not, use a copier to enlarge or reduce the page accordingly.

T-nut Hole ○
Mark only on front half of each side piece after pieces have been cut out. (See paragraph IV-C.)

Orientation Line

#3 SIDE
(R/L) PIECE
(1/2 Pattern B)

Inner Edge

PATTERNS
PAGE 4

@lfmiller10/15/02

Y-Strut Centerholes Ruler

Fig. 4a

